



VKO VIBRADOR SIN DESCARGA

SEPARADOR DE PIEZAS



COMPUERTA DE VACIADO



PISTON DE LA TAPA FÓNICA



DESAGÜE



CUADRO ELÉCTRICO



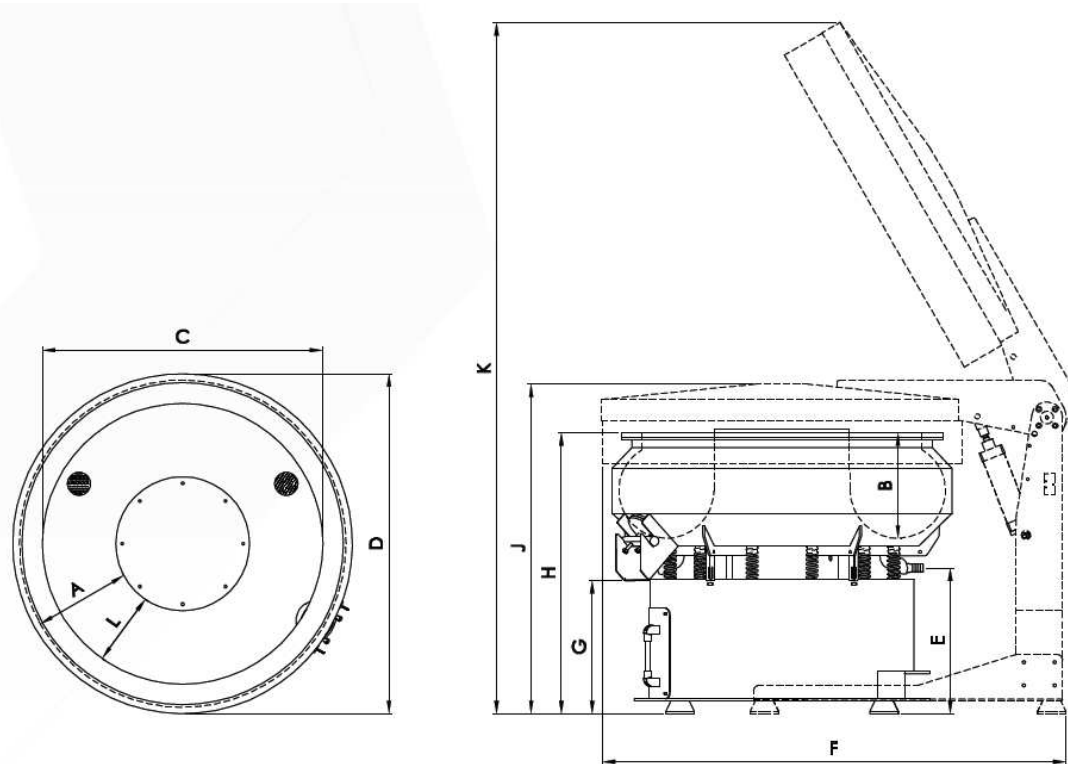

		VKO 75	VKO 150	VKO 250	VKO 350	VKO 500	VKO 650	VKO 1000	VKO 1300
A	mm	230	240	320	370	420	470	530	580
B	mm	270	340	400	420	470	530	600	625
C	mm	600	800	970	1100	1150	1300	1600	1700
D	mm	740	1000	1220	1320	1440	1620	1920	2150
E	mm	500	500	525	525	550	550	650	650
F	mm	1220	1470	1670	1790	1860	2100	2400	2520
G	mm	470	470	500	500	500	500	600	600
H	mm	850	900	1050	1100	1150	1200	1400	1450
J	mm	1050	1100	1250	1300	1350	1400	1600	1650
K	mm	2030	2220	2500	2680	2820	3050	3520	3680
L	mm	200	200	230	280	310	330	400	460

	MEDIDA	VKO 75	VKO 150	VKO 250	VKP 350	VKO 500	VKO 650	VKK 1000	VKK 1300
CAPACIDAD	Lt	76	150	275	348	505	690	1075	1335
POTENCIA MOTOR	Kw	0.7	1.1	1.9	1.9	2.5	5	7	10
PESO	Kg	160	320	550	610	680	1300	1800	2010

VOLTAJE 380/50 V/Hz
VELOCIDAD 1500 rpm
ESPEJOR POLIURETANO 15-25mm